



**THE NEW MINI COUNTRYMAN.**



# ADD STORIES.

The people you never hear from are always the ones with the stories to tell. Chances are that they're in a MINI Countryman, living each day like an adventure. It's a versatile, five-seater Sports Activity Vehicle that's more comfortable than ever. With powerful engines and some serious off-road capabilities, it tackles even the trickiest terrain with ease. So what are you waiting for? The world won't explore itself.

Details of fuel consumption and CO<sub>2</sub> emissions for all models, as required under EU law, can be found in the Technical Data section beginning on page 48.

For more information on the options available for each model, contact your MINI dealer or visit [mini.com/configurator](http://mini.com/configurator)



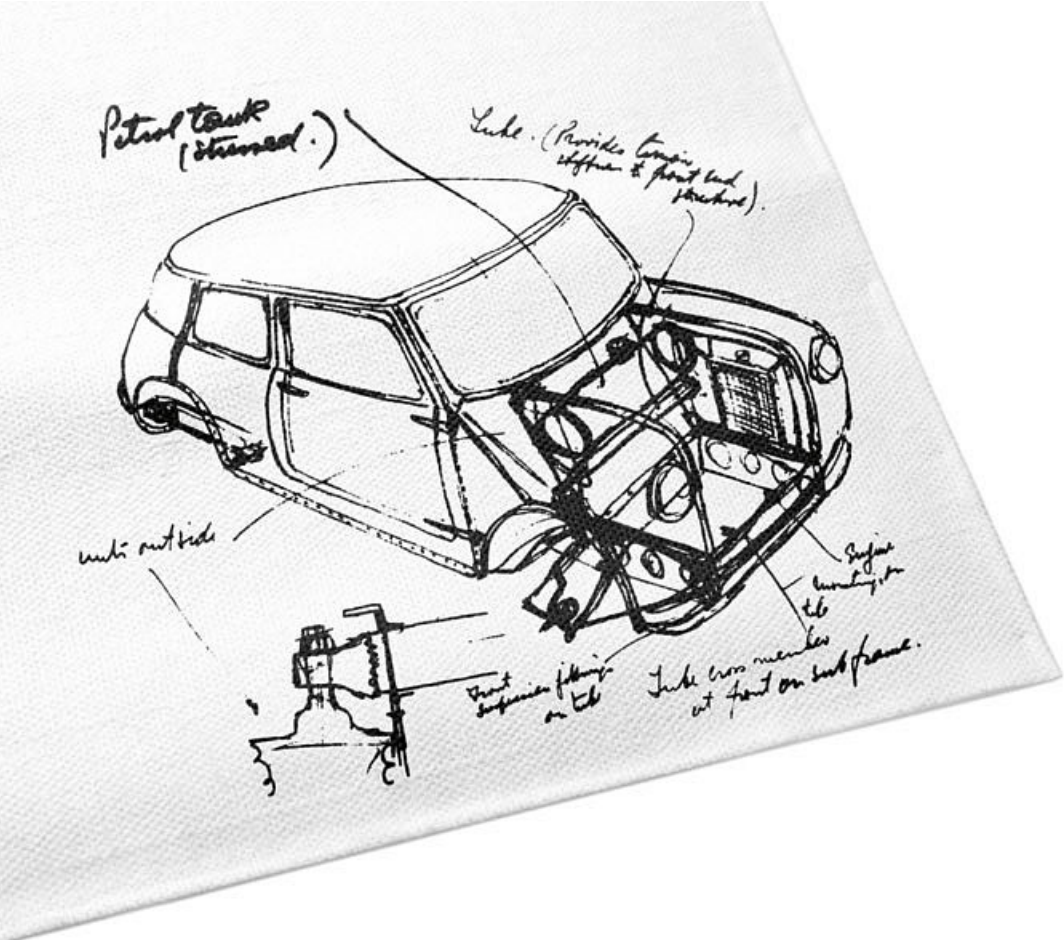

## MAKING THE MINI: BREAKING THE MOULD.

When Sir Alec Issigonis sketched his initial idea for the Mini on a tablecloth in 1956, his innovative compact design was the perfect response to some of the biggest automotive questions of his era. Almost everything about it was unconventional: he increased the track width as far as he could, mounted the engine lengthwise, and positioned the instrument cluster centrally for both left and right-hand drive. This ensured maximum space inside the car. The concept was unprecedented – and his revolutionary Mini soon became an icon.

The first ever Countryman available to buy was the Austin Mini Countryman in 1960. A roomy estate with a long wheelbase and robust wooden appliques, it was designed for trips through the country. With more space than usual and all the charm of a classic Mini, it won fans the world over.

Motorsport legend John Cooper saw star racing potential in the original Mini – so he created a model for the track. Braking, inducing oversteer and then drifting around corners became effortless for rally drivers, thanks to its light weight and short overhangs. Racing around tight bends at high speed, now synonymous with the classic MINI go-kart feeling, laid the foundation for a succession of spectacular wins at the Monte Carlo rally. Here, the Mini proved that agile handling beats sheer power, every time. To honour Cooper’s vision, the thoroughbreds of the MINI range bear the name John Cooper Works.

The compact design of Alec Issigonis and racing pedigree of John Cooper have defined the Mini from the very beginning and remain hallmarks of every iteration to this day. Their legacy of innovation lives on in the latest MINI – and the cutting-edge technology within.







## DISCOVERY IS DESTINY.

You'll feel it in the first few metres: as big as it feels on the inside, the new Countryman is still a MINI through and through. Gliding through the city, coasting through the mountains – it's all effortless. It's just under 4.3 metres long, which means it has some serious luggage capacity in addition to ample legroom. There's also a range of built-in features designed to make epic tours even easier and breezier, like the picnic bench, MINI Connected and the MINI Find Mate.

# THE ONLY THING THAT SHOULD STOP YOU IS THE VIEW.

Main roads will only take you so far. Where the tarmac ends, the adventure really begins. And in the MINI Countryman, the only thing that's going to stop you is the view. Luckily there's a cushioned picnic bench for moments just like these. Just pull it out from beneath the loading shelf and soak up the sunset.

The loading shelf, fastening straps and lashing eyes in the optional storage package keep luggage in place and ensure optimal weight distribution. The luggage compartment also comes with extra LED lights and a 12-volt socket – perfect for powering a coolbox.



# LUGGAGE, MEMENTOS, MEMORIES ...

Destined for higher things: If the luggage space available somehow isn't enough, you can find even more storage options in the high-quality MINI Original Accessories range, like the roof rail system for the luggage rack and roofbox.

MINI Original Accessories  
[mini.com/accessories](http://mini.com/accessories)



# ... TAKE IT ALL WITH YOU.



Great views guaranteed: The optional panoramic glass roof provides a clear view of the sky above and makes the interior feel roomier. The front section opens and slides back electronically. If it gets too bright, there's also a blind for the tinted glass.



You can use the luggage space in the MINI Countryman in any number of ways: the load-compartment floor folds away and the rear backrests fold down in a 40:20:40 split. The rear seat bench slides forward to provide even more room, and splits in a 40:60 arrangement.

Luggage area, width x height x depth:  
859 x 718 x 813 mm  
Through-loading depth with rear seats  
folded down: 1595 mm

The backlighting of the three MINI Yours Interior Styles comes into its own in darkness, bringing an atmospheric glow to the inside of your MINI at night.

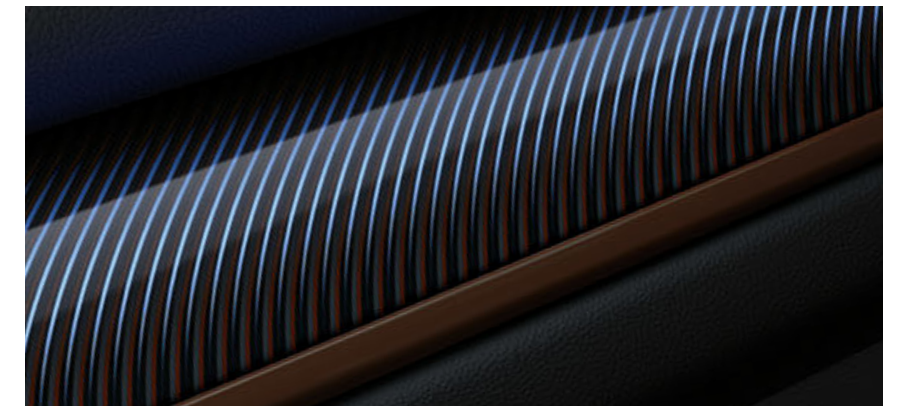

# FIND YOUR COUNTRYMAN.

On the following pages, you'll get your first look at all the ways in which you can personalize your MINI Countryman. Let's start with the essentials: the engine room. You can choose from 3 turbocharged petrol and 3 turbocharged diesel engines, or go for a cutting-edge plug-in hybrid with 6-speed Steptronic transmission and electronic ALL4 all-wheel drive. All engines use the powerful and efficient MINI Twin Power Turbo technology.

5 of the engine variants – 3 petrol, 2 diesel – are fitted with a track-style sequential 6-speed manual gearbox as standard. 6-speed Steptronic transmission is available upon request for One/D and Cooper models, while an 8-speed Steptronic gearbox is an option for Cooper D and Cooper S variants (fitted as standard on the Cooper SD). What's more, intelligent ALL4 all-wheel drive in Cooper/D and Cooper S/SD models ensures optimum traction on all road surfaces. See page 36 for details. For a quick and easy model overview, see the fold-out page on the right.

Optional MINI Driving Modes adapt the performance of your MINI to match your mood and the road conditions. In the MID and GREEN modes, optional Dynamic Damping Control softens the suspension to keep the drive enjoyably smooth. If you want to feel like you're tearing up tarmac in a go-kart, select SPORT mode.

Pictured right: the Cooper in the exclusive Chestnut paint finish (for MINI Countryman only), with roof rails, side-skirt attachments in satin white aluminium, plus 19" MINI Yours Masterpiece light-alloy wheels in exclusive Dark Spectre Grey with burnished rims.

Details of fuel consumption and CO<sub>2</sub> emissions for all models, as required under EU law, can be found in the Technical Data section beginning on page 48.







## ONE.\*

The adventure starts here. Choose from a 1.5-l 3-cylinder petrol engine that delivers 102hp/75 kW or a 1.5-l 3-cylinder diesel unit with an output of 116 hp/85 kW. Both feature MINI Twin Power Turbo technology. High-gloss Black finish for the fins on the radiator grille, side scuttles and tailgate handle trim. Exterior mirror caps in Matt Black.

\* Available from July 2017.

## COOPER.

A 1.5-l 3-cylinder petrol engine (136 hp/100 kW) and a 2.0-l 4-cylinder diesel version (136 hp/100 kW) offer a handy blend of oomph and economy. A classic MINI contrast colour is available at no extra cost for the roof and exterior mirror caps. The exhaust pipe comes with a Chrome trim. Bonnet stripes available on request.

## COOPER S.

Better, faster, stronger: With a 2.0-l 4-cylinder petrol engine (192 hp/141 kW) or a 2.0-l 4-cylinder diesel unit (190 hp/140 kW), the Cooper S packs the biggest punch. Hallmarks include the red S at the rear, side scuttles and the mesh radiator grille with inner Chrome trim. Twin Chrome-plated exhaust pipes (right and left). MINI ALL4 Exterior Optic package available on request.

## COOPER S E ALL4.

Slick combo: A 3-cylinder petrol engine (136 hp/100 kW) at the front with an 88-hp/65-kW e-motor at the rear axle. Instantly recognizable via the gold MINI Plug-in Hybrid logo on the side scuttles and at the rear. Charging port at left side scuttle. Yellow Cooper "S" on the front grille and tailgate. Single Chrome-plated tailpipe at rear apron on the left-hand side.





## FAST-FORWARD TO THE FUTURE.

The new MINI Countryman Plug-in Hybrid combines an electric motor and battery with a conventional petrol engine to offer drivers the best of both worlds. The result is emission-free fun out on the road, at practically no cost to space or practicality. Thanks to its high-voltage, lithium ion battery, the Plug-in Hybrid can drive electric-only and virtually emission-free for up to 42km. The e-motor backs up the petrol engine via the boost function and enables electric all-wheel drive.

The central display (1) shows the power distribution between the two engines. A combi display (3) replaces the rev counter, and shows the available power. The battery can be charged both during the journey and externally at any 230-volt power supply via the supplied cable (2). A full charge (from 0%) takes approx. 195 minutes.

### MINI ELECTRIC



# FIND OUT ALL THAT WE'VE PACKED IN.

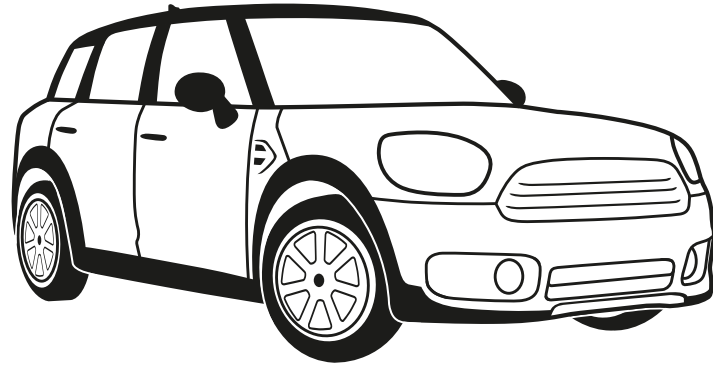

If the practically endless list of individual equipment options puts your head in a spin, keep things simple. Spruce up your MINI Countryman with one (or more) of our equipment packages. The features in each bundle have been carefully grouped together to complement each other – making your decision that much easier.

What's more, you can easily combine the four options here with other packages, like the Wired (p. 41), John Cooper Works Exterior/Interior, MINI ALL4 Exterior Optic (p. 32) and Chrome Line Exterior/Interior bundles.

- |   |   |   |   |                          |
|---|---|---|---|--------------------------|
| ● | ○ | ○ | ○ | SALT.                    |
| ● | ● | ○ | ○ | PEPPER.                  |
| ● | ● | ● | ○ | CHILI.                   |
| ● | ● | ● | ● | JOHN COOPER WORKS CHILI. |

The Salt, Pepper, Chili and John Cooper Works Chili packages vary in size, each expanding on the one before it (see above). They also match smaller packages with complementary individual equipment options. See the fold-out page on the right for details. For information on availability, check online or contact your nearest MINI dealer.

[mini.com/configurator](http://mini.com/configurator)





## SALT.

The Salt equipment bundle adds a dash of extra comfort and connectivity to the mix. It includes velour floor mats, the lights and storage packages, automatic air conditioning and fog lights.

## PEPPER.

Spice things up a bit with the Pepper package. It has everything in the Salt bundle plus the MINI Excitement package: ambient lighting with toggle switch in the headliner, waterfall lighting, lighting for door handles and MINI logo projection. You also get:

- + Keyless Comfort Access system
- + Sports leather steering wheel
- + Front armrest
- + Exterior mirror caps in body colour for One/D
- + 17" Imprint Spoke for One/D and Cooper/D

## CHILI.

On top of all the extras in the Salt and Pepper bundles, the Chili package packs even more racetrack flair and cutting-edge technology into your MINI. Here's what you get:

- + Multifunction option for sports leather steering wheel
- + Cord cloth/leather sport seats
- + MINI Driving Modes
- + Cruise control with brake function
- + LED headlight technology with adaptive light distribution and fog lights
- + 17" Channel Spoke for One/D and Cooper/D
- + 18" Pair Spoke for Cooper S/SD

## JOHN COOPER WORKS CHILI.

This package combines everything in the Salt, Pepper and Chili options with the John Cooper Works Exterior and Interior packages (both available separately) for maximum motorsport atmosphere. It includes the following:

- + John Cooper Works sports leather steering wheel
- + Performance Control for One/D and Cooper/D
- + Dynamic rear roof spoiler
- + John Cooper Works aerodynamic kit
- + Anthracite roof liner
- + Stainless steel pedals and footrests
- + John Cooper Works door sill finishers and gear lever knob
- + Sports suspension (available at no extra cost)
- + 18" John Cooper Works Thrill Spoke

# DIFFERENT SHADES OF ADVENTURE.



Moonwalk Grey  
(standard colour)

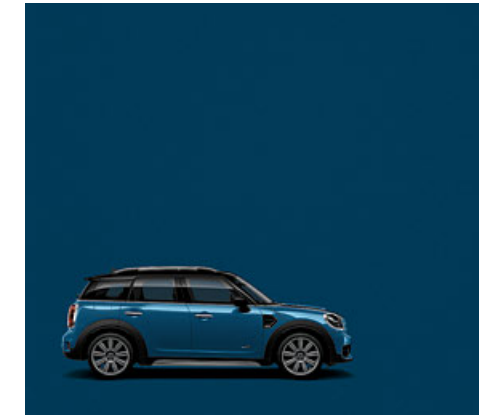

Island Blue

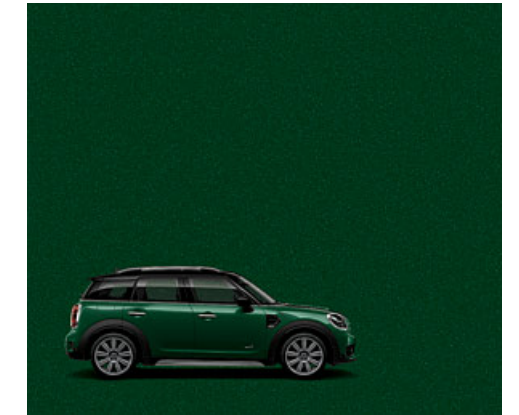

British Racing Green

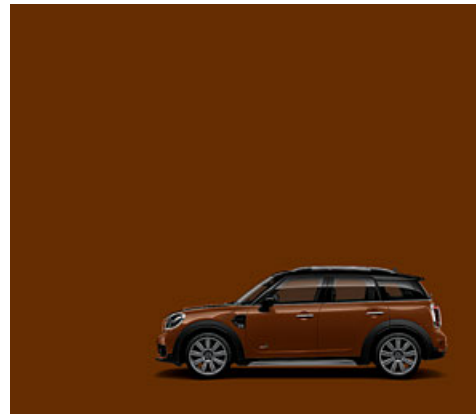

Chestnut

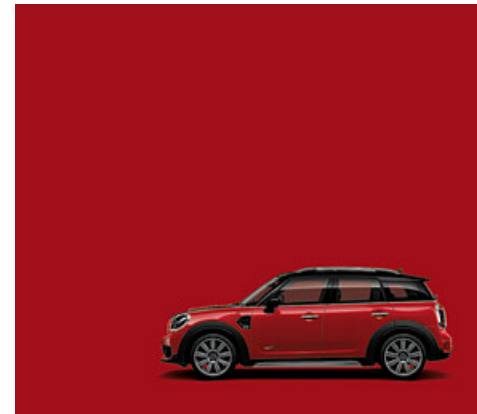

Chili Red

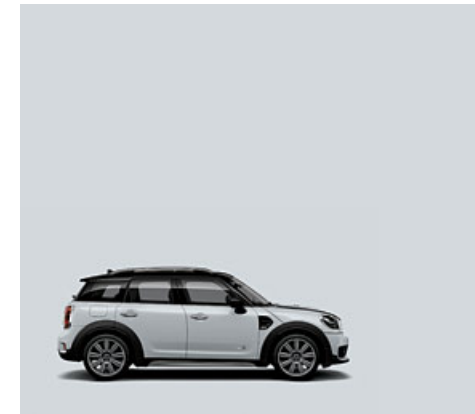

Light White

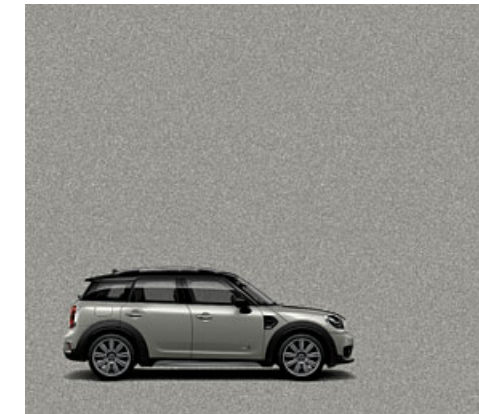

Melting Silver

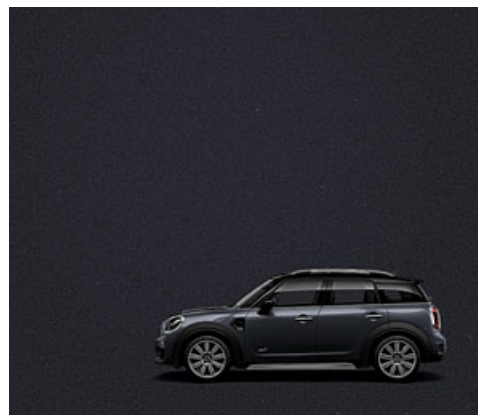

Thunder Grey

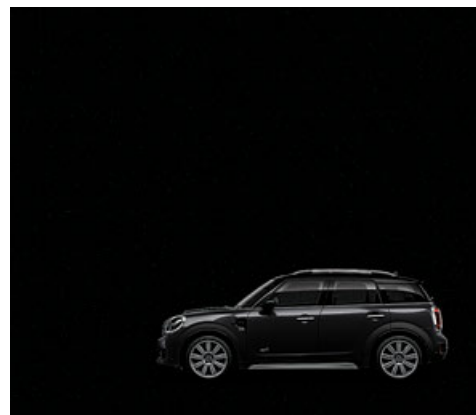

Midnight Black

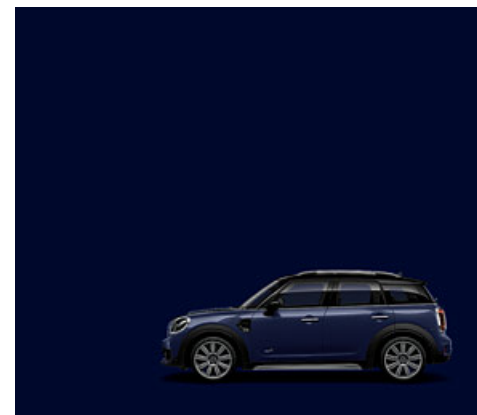

Exclusive finish:  
MINI Yours Lapisluxury Blue

Roof and exterior mirror caps.

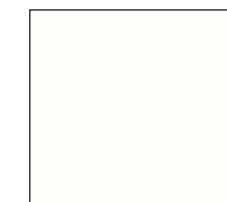

Aspen White

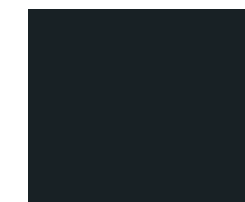

Jet Black

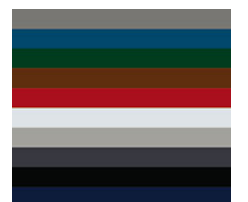

Body colour



# 13 WHEEL RIMS – ONE DECISION.

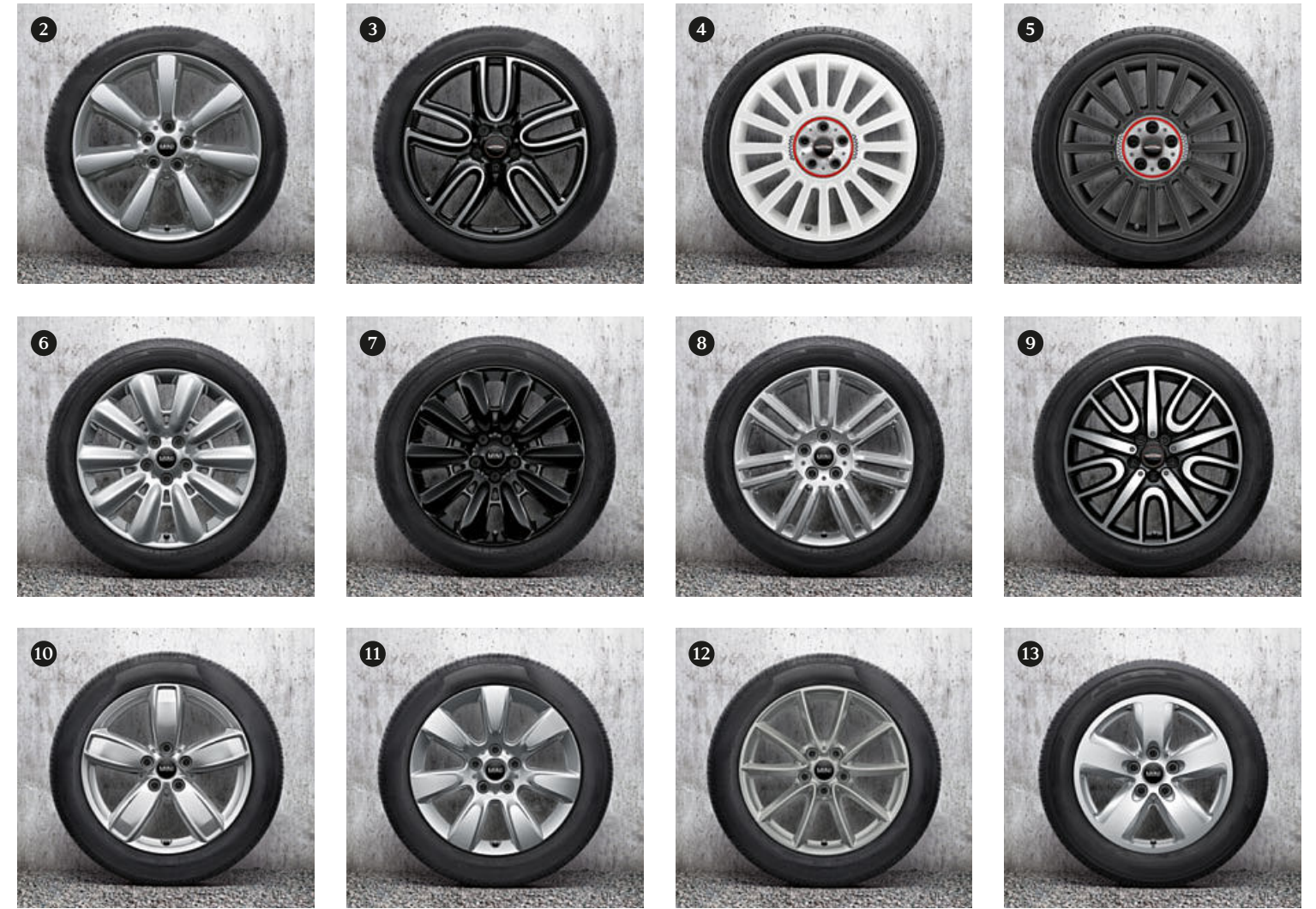

1 19" MINI Yours Masterpiece, burnished

2 19" Edge Spoke

3 19" John Cooper Works Course Spoke, burnished

4 19" John Cooper Works Rallye Spoke, White\*

5 19" John Cooper Works Rallye Spoke, Grey\*

6 18" Pin Spoke

7 18" Black Pin Spoke

8 18" Pair Spoke

9 18" John Cooper Works Thrill Spoke, burnished Anthracite

10 17" Channel Spoke

11 17" Imprint Spoke

12 17" Light Spoke, Grey\*\*

13 16" Revolite Spoke

\* Available at [mini.com/accessories](http://mini.com/accessories)  
 \*\* Exclusive wheel rim fitted as standard on the MINI Cooper S E ALL4.



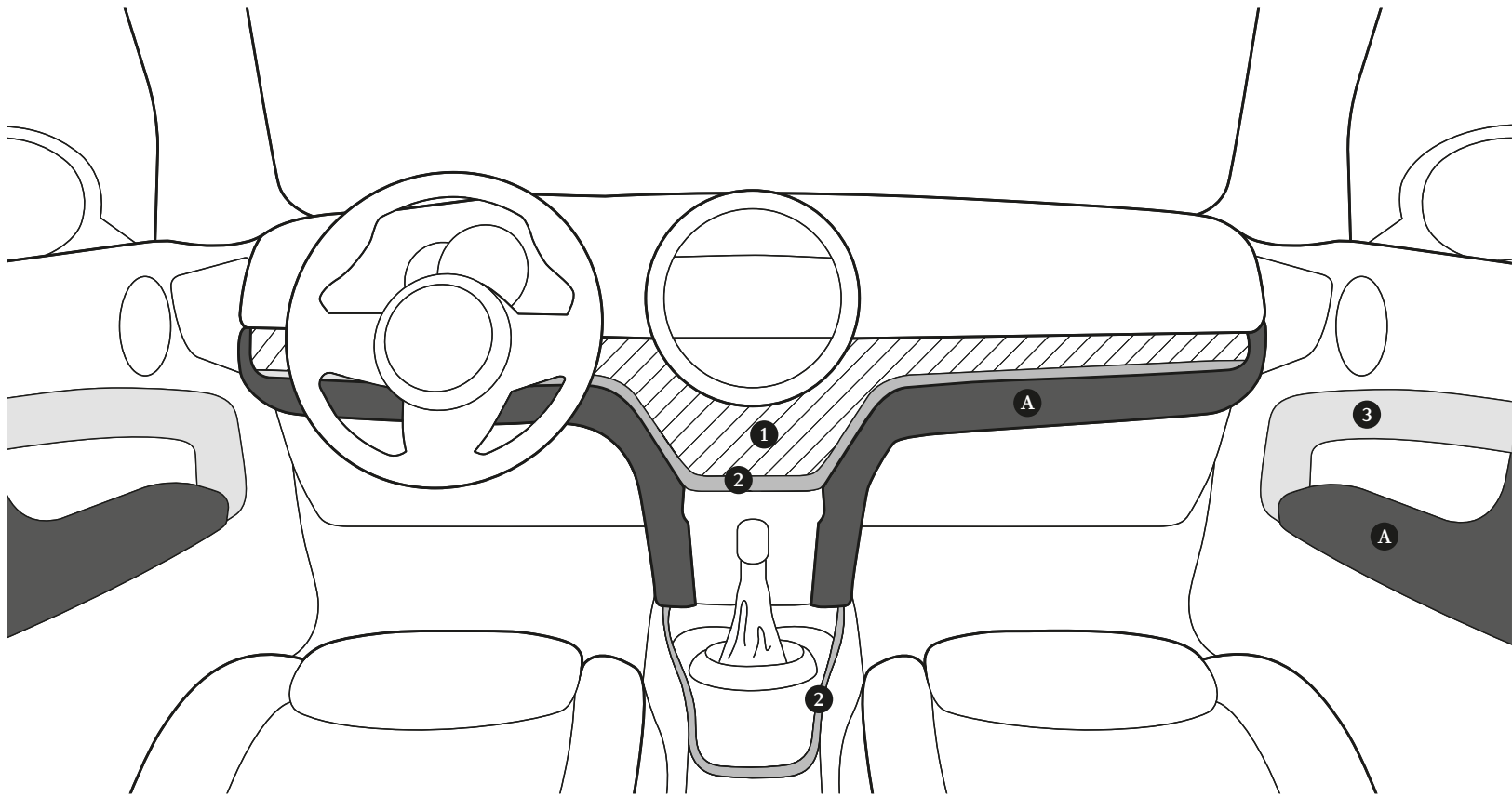

## INTERIOR ELEMENTS IN DETAIL.

4 high-quality Interior Styles are available for personalizing the inside of your MINI – 3 of them with MINI Yours Illumination. Choose a style for the central design elements: decorative cockpit trim (1), a matching contrast trim (2) and the decorative door trims (3). Then select a suitable colour from the Colour Line (A) range for the kneepads and armrests in the doors. The fold-out page on the left has all the details of the Piano Black Interior Style in combination with the British Oak Colour Line; the fold-out on the right shows the MINI Yours Chestnut illuminated Interior Style with the Carbon Black Colour Line.

### The 4 optional Interior Styles.

#### Piano Black Interior Style.



Piano Black



Dark British Oak



Piano Black

#### MINI Yours Piano Black illuminated Interior Style. (Illumination colours defined by pinstriped ambient lighting.)

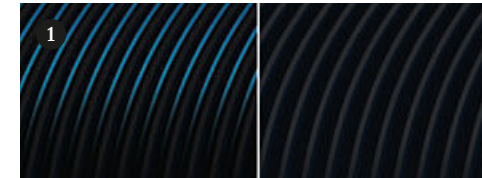

Piano Black illuminated, Piano Black



Hazy Grey

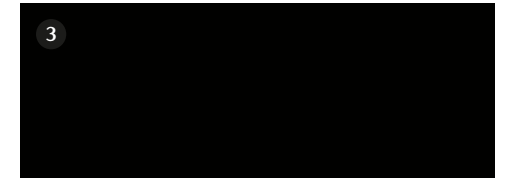

Piano Black

#### MINI Yours British Oak illuminated Interior Style. (Red and blue graphics for illumination colours. Painted and backlit plastic surfaces. No real wood.)

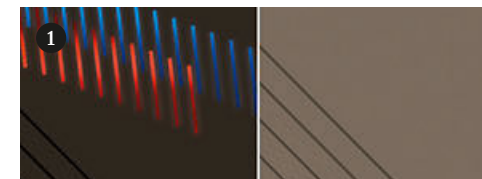

British Oak illuminated, British Oak



Hazy Grey



British Oak

#### MINI Yours Chestnut illuminated Interior Style. (Illumination colours defined by pinstriped ambient lighting.)

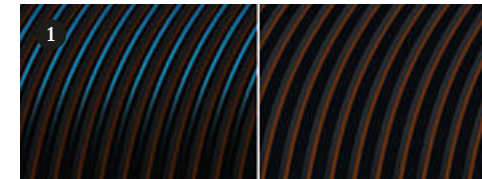

Chestnut illuminated, Chestnut



Chestnut

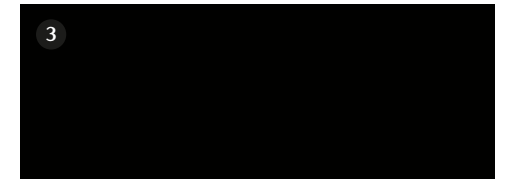

Piano Black

#### 4 Colour Lines.



Malt Brown



Satellite Grey



British Oak

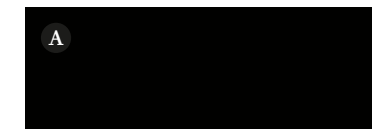

Carbon Black



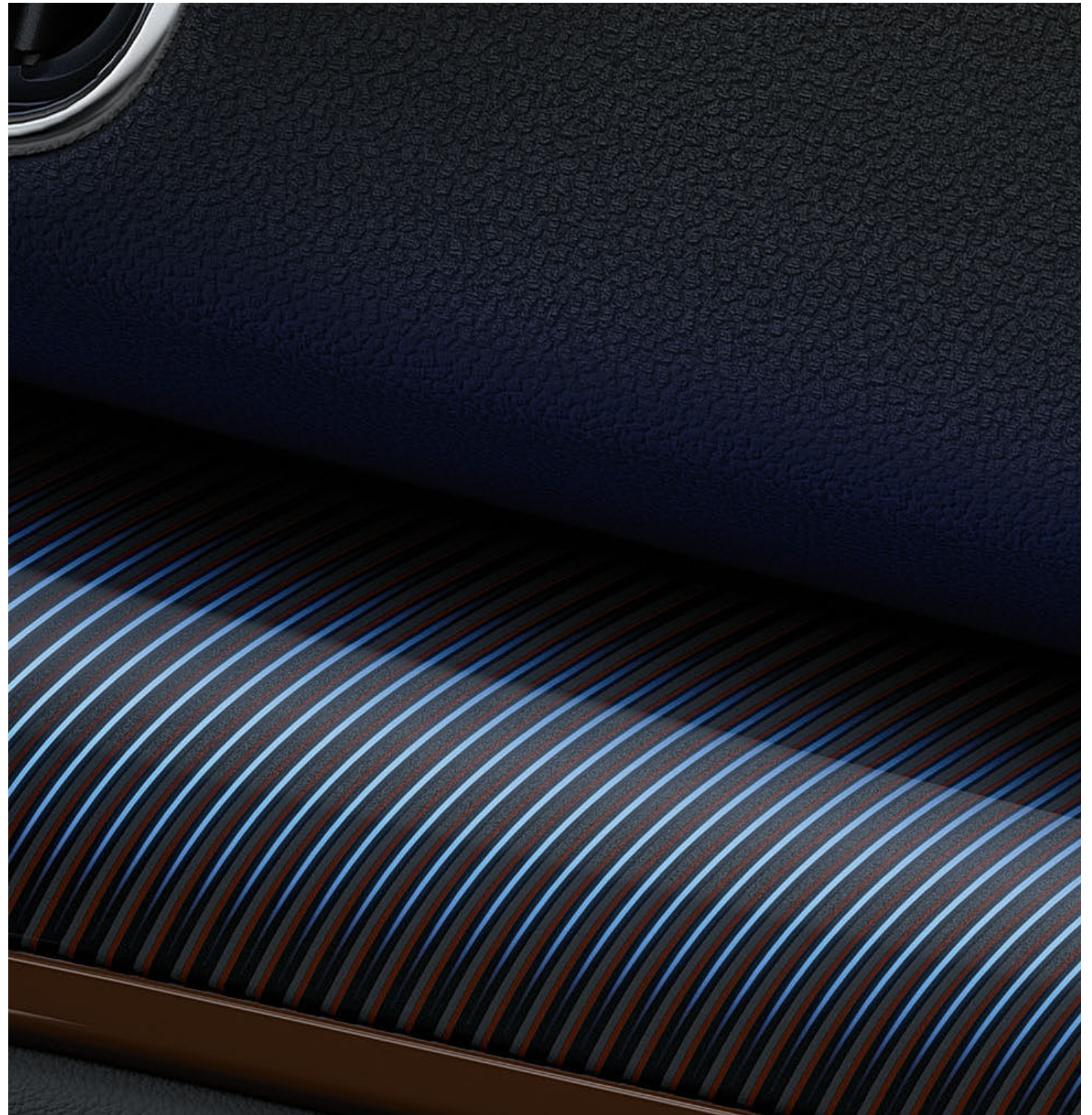

# THE EDGE OF YOUR SEAT HAS NEVER BEEN SO COSY.



Chester leather  
sport seat,  
British Oak



John Cooper Works  
Dinamica/leather  
sport seat,  
Carbon Black

## AT HOME IN SECONDS.



Cross Punch leather\*  
sport seat,  
Carbon Black



Cord cloth/leather  
sport seat,  
Carbon Black



Black Pearl cloth/leatherette  
sport seat,  
Carbon Black



Lounge leather\*  
sport seat,  
Satellite Grey



MINI Yours Lounge leather\*  
Carbon Black,  
incl. Dinamica armrests in  
Carbon Black

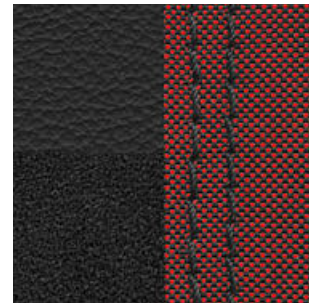

John Cooper Works  
Dinamica/leather,  
Carbon Black,  
incl. Dinamica armrests in  
Carbon Black



Lounge leather\*  
Satellite Grey,  
incl. leatherette armrests in  
Carbon Black



Chester leather\*  
British Oak,  
incl. leatherette armrests in  
Carbon Black



Cross Punch leather\*  
Carbon Black,  
incl. leatherette armrests in  
Carbon Black

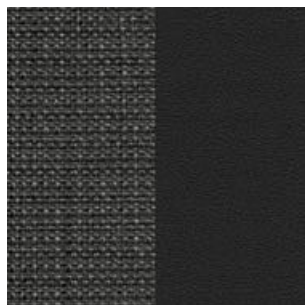

Black Pearl cloth/leatherette  
Carbon Black,  
incl. Black Pearl armrests in  
Carbon Black



Cord cloth/leather  
Carbon Black,  
incl. Cord armrests in  
Carbon Black

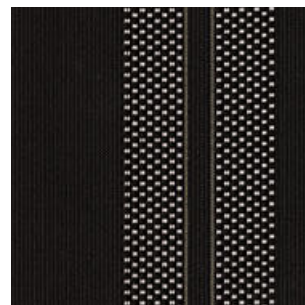

Double Stripe cloth  
Carbon Black,  
incl. Carbon Black armrests

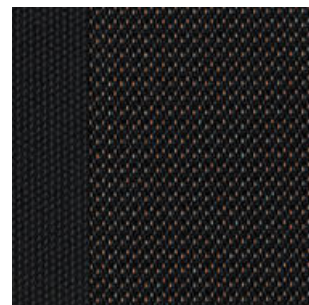

Firework cloth  
Carbon Black,  
incl. Carbon Black armrests



The optional electric front seat adjustment features a memory function that remembers your favourite seating position, including armrest, recline and lumbar support settings.



## MINI YOURS.

The Carbon Black MINI Yours seat in luxurious Lounge leather isn't just made – it's crafted. The smooth feel of the leather against your hand, the detailed stitching of the Union Jack in the headrest, the braided edging ... the beauty is in the detail.

[mini.com/configurator](https://www.mini.com/configurator)

\* Leather upholstery includes seats (base and backrest), and front and rear headrests.



# BIG ON SMALL DETAILS: MINI YOURS.

The MINI Yours customization programme provides a wealth of options for those who prize individuality and refined style. The range represents the best of British craftsmanship, and each item has its own story to tell.

Here are a few examples: the MINI Yours sports leather steering wheel including soft nappa leather and contrast stitching, burnished 19" MINI Yours Masterpiece wheel rims, illuminated MINI Yours Interior Styles and the spectacular exterior colour MINI Yours Lapisluxury Blue – a deep shade of ultramarine.

The MINI Yours logo with Union Jack and sewing needle features on all MINI Yours leather upholstery. The MINI Yours seat in Carbon Black is made from the finest leather. It comes with braided edging, a Union Jack on the back of the headrest, plus dinamica armrests in the same colour.



## JOHN COOPER WORKS. SPORTS PACKAGES FOR THE MINI COUNTRYMAN.



For an authentic race-car feeling outside and in, look no further than the John Cooper Works Exterior package. Dashing looks are guaranteed thanks to exclusive 18" John Cooper Works Thrill Spoke burnished wheels, the aerodynamic kit and the John Cooper Works rear spoiler. Performance Control counteracts understeer, and a stiffer sports suspension system can be fitted at no extra charge.

The John Cooper Works Interior package comes with an Anthracite headliner, John Cooper Works sports leather steering wheel with multifunction option, sport seats for One/D and Cooper/D, stainless steel pedals, the John Cooper Works gear lever knob plus optional John Cooper Works dinamica seats with Red trim and Carbon Black dinamica armrests. Both packages include custom door sill finishers and make up part of the John Cooper Works Chili equipment bundle (p. 16).



## JOHN COOPER WORKS TUNING KIT: HEAR THE DIFFERENCE.



Look forward to a spine-tingling motorsports experience every time you get behind the wheel, thanks to the John Cooper Works Tuning Kit\* featuring a Bluetooth-controlled valve exhaust silencer system. This sophisticated system increases performance and lets you set the tone: Sport mode delivers a satisfyingly powerful engine sound that is still suitable for everyday driving,

\*Available from summer 2017.

while Track mode is exclusively for use on the racetrack, where it generates an almighty roar. The tailpipe finishers are optionally available in either Carbon or Chrome.

John Cooper Works Tuning Kit  
[mini.com/accessories](http://mini.com/accessories)

# PUTTING THE COUNTRY INTO COUNTRYMAN.

The MINI ALL4 Exterior Optic package brings out the tireless off-road workhorse in the MINI Countryman. Bumper attachments in high-gloss Black and an underride guard feature at both the front and rear, while the standard roof rails and side skirts in satin white aluminium underscore the SAV's ready-for-anything profile. The package is also available without ALL4 all-wheel drive.

MINI Original Accessories  
[mini.com/accessories](http://mini.com/accessories)



# GO YOUR OWN WAY.

The best views are at the top, and ALL4 gets you there. The intelligent all-wheel drive system provides supreme traction when you need it, down dirt tracks, cobbled streets or even across the snowy plains. Now you can really run wild.





# WITH ALL4 ANYTHING'S POSSIBLE.

The ALL4 all-wheel drive in the MINI Countryman is an intelligent torque vectoring system that maximizes traction on virtually any surface. Its electro-hydraulic multi-disc clutch\* is linked to Dynamic Stability Control and smoothly varies the amount of drive torque distributed from the MINI Twin Power Turbo engine to the front and rear axles according to the driving situation. That all means supreme traction, maximum stability and even more fun cruising around corners.

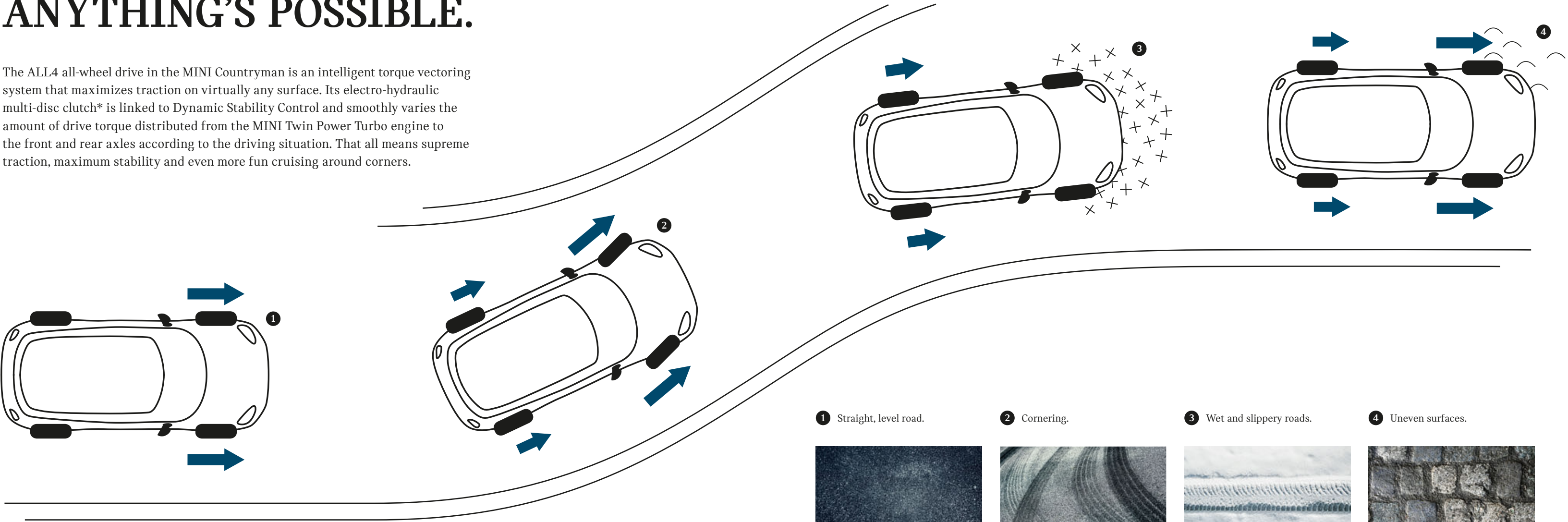

 Drive torque

1 Straight, level road.



To maintain efficiency in normal driving situations, e.g. on straight, level roads, the system diverts 100% of the torque to the front axle.

2 Cornering.

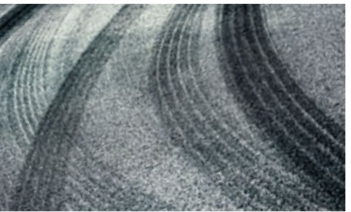

ALL4 allocates enough torque to the rear axle to counter the onset of over/understeer and increase stability.

3 Wet and slippery roads.



More torque is directed to the rear axle – in some cases up to 100% – when a loss of grip occurs at the front. This counteracts understeer and ensures optimal traction.

4 Uneven surfaces.



ALL4 rapidly allocates the optimum amount of power to each axle to ensure maximum traction on uneven roads.

\* Different ALL4 technology is used in the MINI Countryman Plug-In Hybrid (page 15).

# THE BEST JOURNEYS BEGIN WITH PEACE OF MIND.

1 Now you'll never lose sight of the important things. The MINI Head-Up Display projects key driving information into the driver's line of sight without obstructing his view of the road. Depending on the optional equipment fitted, this data can include speed limits, navigation instructions and cruise control settings.

2 The optional Bi-LED light for the anti-dazzle and high-beam technologies is a clearly visible beacon out on the road. It's like having a lighthouse lamp fitted to your car. The LED cornering light follows and illuminates the curve of the road, while the LED fog lights and MINI Original LED additional headlights ensure optimum visibility when the weather takes a turn for the worse. Whatever the weather, the omega-shaped daytime running

lights in the LED headlights remain a hallmark of the MINI Countryman design. The High Beam Assist – part of the Driving Assistant – recognizes oncoming vehicles. At speeds of 50 km/h and above, it automatically switches the high beam off to prevent glare affecting oncoming traffic – and back on again once the vehicles have passed. It also recognizes when there is sufficient light, e.g. in built-up urban areas, and dims the lights accordingly.

3 If desired, the tailgate of the MINI Countryman can open and close electronically. All you need is the Comfort Access system: the Easy Opener function means you can open the boot just by waving your foot under the rear of the vehicle.

4 The Park Assist helps you find a suitable parking space and makes parallel parking easy. All you have to do is brake and accelerate as required.

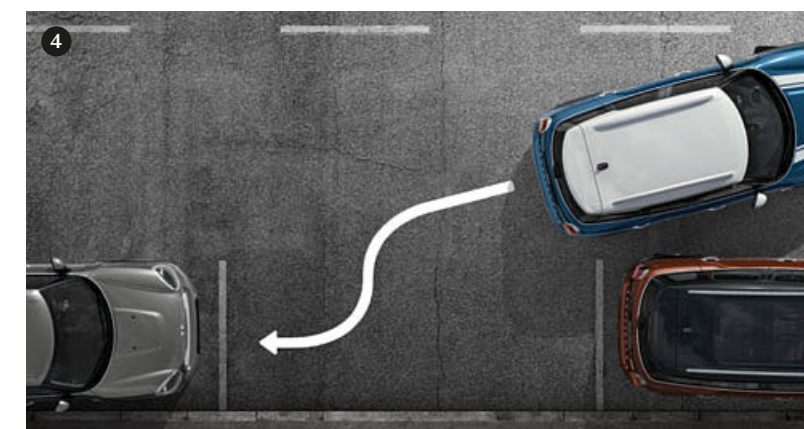
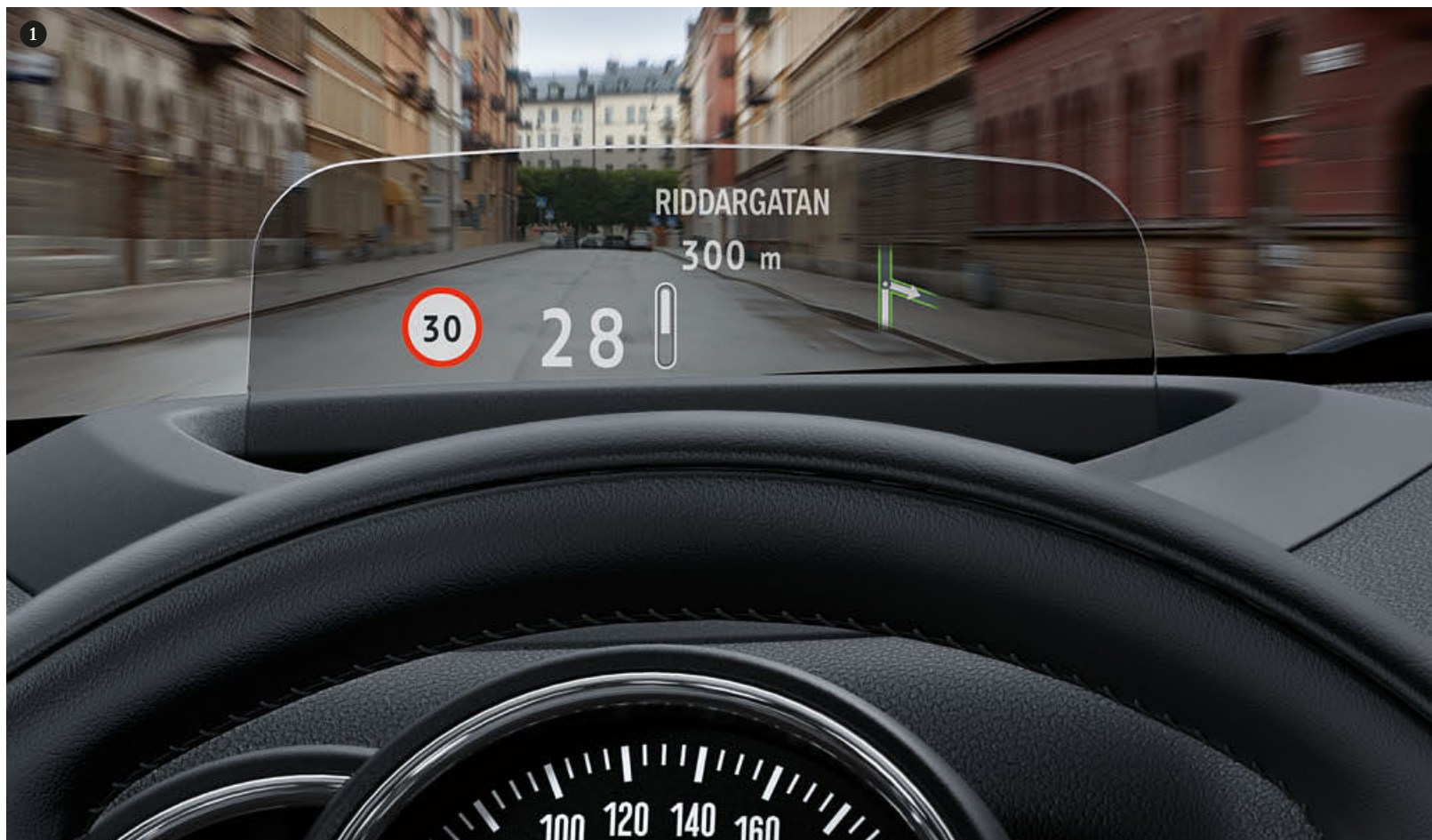



# MINI CONNECTED: HELLO WORLD.

Between MINI Connected and its compatible apps, you've got everything you could need to take the hassle out of your journey – and inject a few more thrills into it. Be it loading up your very own smartphone-based personal assistant or choosing music from one of countless playlists, you can do it all from behind the wheel.

The development of MINI Connected is an ongoing process. Updates are sent directly to customers – and integrated into the product – via the Open Mobility Cloud. This means that app screens, interfaces and other features shown on the following pages may soon change. And if they do, it'll be change for the better. For the latest information on MINI Connected features and availability in your country, go online at

[mini.com/connected](http://mini.com/connected)

WIRED



With the Wired package you can take full advantage of the MINI Connected world of infotainment. It comes with the Professional navigation system with 22.4-cm/8.8-inch touchscreen (plus operation via the MINI Touch Controller on the centre console) and in-car wireless charging (plus phone calls via an external antenna). Other features include a multifunction steering wheel, voice control, 3D satellite map view, MINI Connected, 20 GB of entertainment storage and much more.

# LEAVE ORGANIZED. ARRIVE ENERGIZED.

## LET MINI CONNECTED SHOW YOU THE WAY.

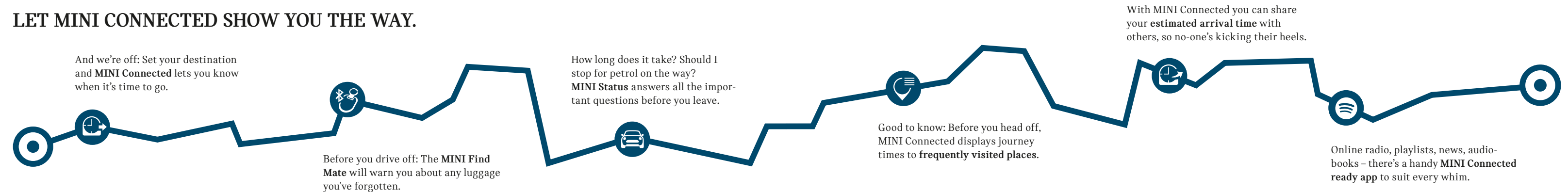

## MINI CONNECTED FUNCTIONS AT A GLANCE:



### VEHICLE STATUS AND DESTINATIONS.

The **MINI Status** display on your smartphone – in a classic **MINI** design with **Union Jack** – provides a handy overview of key information, such as how far you are from your destination, the current range, and remaining journey time.



### VEHICLE SEARCH.

Not sure where you left your **MINI**? Check your smartphone to find the quickest way back.



### TIME TO GO.

**MINI Connected** sends updates to your smartphone or **Apple Watch**, reminding you when it's time to make your way to a saved or learned destination. The latest online traffic updates are taken into account when calculating the time.



### FREQUENTLY VISITED PLACES.

**MINI Connected** shows all previously learned or saved destinations and calculates the time it takes to reach them from your current location, using real-time traffic information. It saves time – and helps you stay on top of things.



### ONLINE SEARCH.

Going shopping or eating out? Once you've found somewhere suitable using **Online Search**, you can send the address to the navigation system, and the phone number to your smartphone, so you can book a table.



### SHARE YOUR ARRIVAL TIME.

Great for groups of friends coming from all different directions: you can send your arrival time (calculated using real-time traffic updates) to smartphone contacts.



### MINI CONNECTED READY APPS.

An ever increasing number of pre-configured apps for **MINI Connected** allow you to use all your favourite smartphone features on the move. Keep your spirits up with your choice of **Spotify** playlists, podcasts, audiobooks and other music apps.



### MINI FIND MATE.

Never forget a thing. Attach a **MINI Find Mate** tag to your important belongings and, if desired, your **MINI Find Mate** will issue an audio alert if a specified distance between you and your items is exceeded. Your smartphone will show you where the **MINI Find Mate** tag was last detected.



### CALENDAR INTEGRATION.

**MINI Connected** can import all destinations from your smartphone calendar. It saves addresses in the navigation system and reminds you of when you need to leave.



### IMPORT DESTINATION FROM SMARTPHONE TO NAVIGATION SYSTEM.

As long as your smartphone is linked to your vehicle, destinations (learned, saved or imported from your calendar) are guidance starts automatically (depending on equipment fitted).



### ONLINE TRAFFIC MAP.

A real-time traffic check helps you spot and bypass sudden bottlenecks. Use the zoom function to pinpoint alternative routes.



# FORGET ABOUT FORGETTING.

## MINI FIND MATE.

The MINI Find Mate feature is a handy addition to the Wired package. It comes with 2 Bluetooth tags, which you can attach to those things that you just can't go without. The moment you move too far away from the tagged object, you'll receive a notification from the MINI Connected app on your smartphone. The wireless automatic connection between the MINI Connected app and your vehicle helps you navigate close to the last GPS position of the MINI Find Mate tag. The MINI Connected app can keep track of up to 6 MINI Find Mates at once. You can buy more tags from the MINI Lifestyle store.



## CHOOSE YOUR INTERFACE.

### 1 RADIO MINI BOOST.

Fitted as standard, the Radio MINI Boost comes with USB audio and AUX-IN interfaces, a Bluetooth hands-free kit and a 4-line display.

### 3 MINI NAVIGATION SYSTEM.

Leading the way: a first-class navigation system with GPS, TMC and USB updates. Upgrade for the Radio MINI Visual Boost. Easily operated via the MINI Controller.

### 2 RADIO MINI VISUAL BOOST.

Complete with 16.2-cm/6.5-inch screen, ergonomic MINI Controller and MINI Connected interface.

### 4 MINI PROFESSIONAL NAVIGATION SYSTEM.

Included in the Wired package: the 22.4-cm/8.8-inch touchscreen has a brand new design. It's easy to operate and provides a comprehensive overview of all you need to know for your journey. Split-screen functionality means you can use more than one feature at the same time.





# DRIVING THE FUTURE OF MOBILITY.

We have never been so connected – and life has never been so fast-paced. So we need vehicles that can keep up with our hectic lifestyles. And this is why a MINI excels in many different ways. A MINI is all about being yourself, enjoying your journey and turning heads along the way.

But it's also about having the right mindset. This means loving what we do. And recognising the value in certain things, whether it's because they mean something, because they're important or because they look good.

Since 1959, we have strived to retain what sets MINI apart while creating something new. We want to inspire others to help us develop better ways of going places, which we can appreciate today – and in the future.

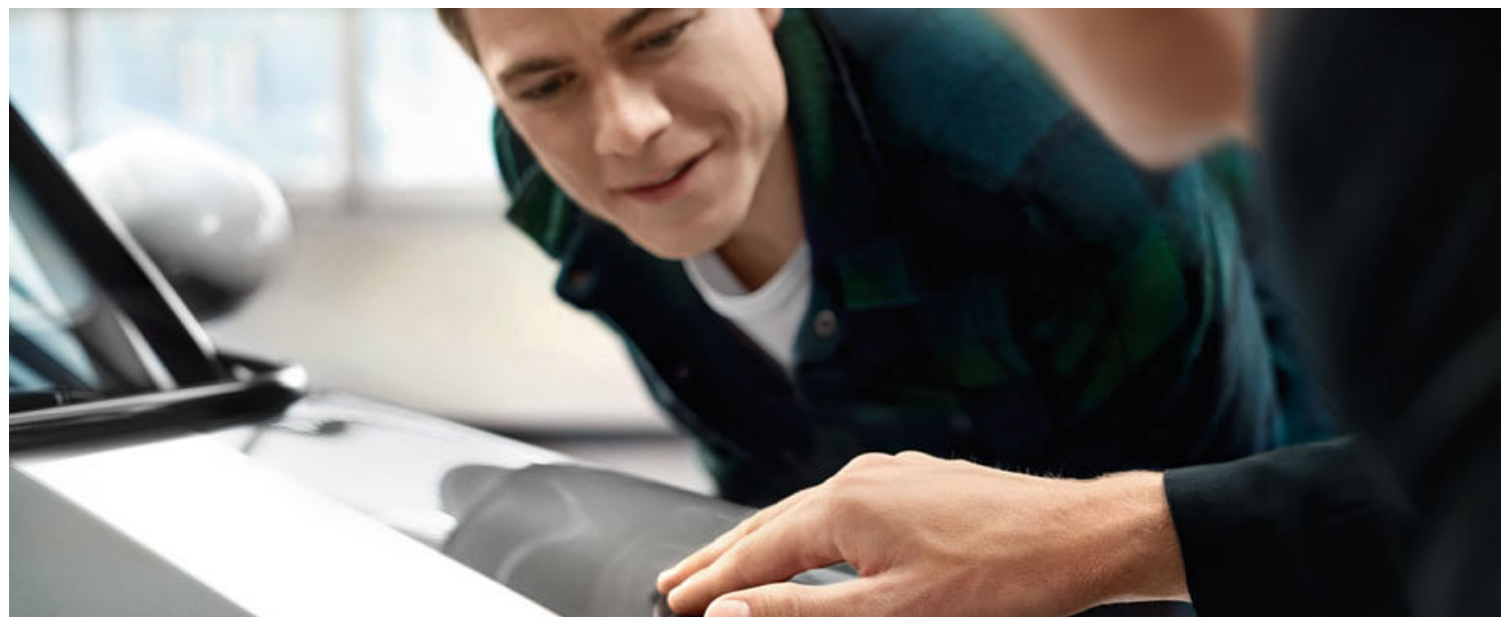

## MINI SERVICE.

### We've got everything covered.

Our service experts are as passionate about your MINI as you are. They're specially trained to keep it in top shape, so for electrical or mechanical defects, cosmetic or bodywork repairs, or even simply fitting MINI Original Parts, your MINI will be in the best possible hands.

### MINI knows best.

Since you can't always think of everything when on the road, your MINI uses its head too. The Condition Based Service feature automatically reminds you when its next service is due, via the MINI Centre Instrument. The MINI Teleservices feature automatically transfers the most important vehicle data to MINI via a built-in SIM card. Your local MINI Service Centre will then contact you to make an appointment if any maintenance is necessary. What's more, in the unlikely event of a breakdown, you can also contact the specialists on our MINI Breakdown Service team directly. If you don't need to use the service, you can deactivate it at any time. The Intelligent Emergency Call option is required to use MINI Teleservices.

### At a glance: MINI Service Inclusive.

Thanks to MINI Service Inclusive and MINI Service Inclusive Plus, there's no need to worry about maintenance and repair costs: a single fixed amount for maintenance covers all the services included in your chosen package for up to 6 years and 120,000 kilometres. It's easy to calculate, and MINI Service Inclusive represents a significant saving in cost compared to individually paid-for trips to your MINI Service Partner. Both packages provide quality you can count on, too: qualified MINI Service specialists, state-of-the-art diagnostics tech and top-quality MINI Original Parts guarantee first-class service, every time, so your MINI retains its value over the years and miles.

### We'll keep your MINI mobile.

MINI Mobile Service and the MINI Accident Hotline are there when you need them, 24 hours a day, 365 days a year. If you have a breakdown, you'll get specialist help every step of the way: we'll send expert technicians to help you on site, dispatch a BMW Group replacement vehicle to get you back on the road, provide car recovery and towing services and more. In the event of an accident, we'll be there for you with a comprehensive range of services. Find out more online at [mini.com](http://mini.com)



## MINI FINANCIAL SERVICES.

### The key to the car of your dreams.

MINI Financial Services\* represents the quickest way to the car of your dreams. With MINI Leasing, you pay to use the vehicle and not a penny more. MORE MINI packages provide a host of attractive extras, such as suitable insurance\*\*, a tailored service deal or even a combination of both.

If you want to own a MINI but stay flexible with your financing, you'll find a favourable deal with MINI Finance. And for total peace of mind, check out MINI Car Insurance\*\*.

Find out more about MINI Financial Services online at [mini.com](http://mini.com) or visit your local MINI dealership.\*\*\*

\* MINI Financial Services is a trade name of BMW Bank GmbH, Heidemannstr. 164, 80939 Munich, Germany.  
\*\* Contractual partner and risk carrier is Allianz Versicherungs-AG.  
\*\*\* Vehicle also includes a service package. See service package agreement for details.

### Warranty.

Every MINI is supplied with a 2-year dealer warranty against manufacturing defects. The MINI dealership where the purchase was made is responsible for honouring the warranty. Repair work can be carried out at any authorized MINI dealer, MINI Service Authorized Workshop or any other service centre authorized by MINI. Defects arising in the first 6 months after purchase are deemed by law to have existed at the time of purchase and the dealer has the onus of proving that the vehicle is not defective due to a manufacturing defect. Every MINI also comes with a 12-year anticorrosion warranty, which covers the vehicle against rusting of the body panels. The painted surfaces of the car are covered by a 3-year warranty. This warranty does not cover damage to the vehicle body or under-body caused by stone impacts, scratches or dents, accident damage or other damage caused by environmental factors. Failure to comply with the service schedule provided by the manufacturer may invalidate this warranty.

### Recycling.

At every stage, from design to disassembly, recycling is central to the MINI philosophy. For example, all the materials used in each vehicle's manufacture are selected because they can be used in the most sustainable and environmentally friendly way possible. That way, every MINI can be efficiently and ecologically recycled when its driving days are finally done. We have been working on this approach since 1994 at the BMW Group Recycling and Disassembly Centre in Munich, the only facility of its kind. Your MINI dealer will be pleased to advise you on the disposal of your old vehicle, or you can visit [mini.com/recycling](http://mini.com/recycling)



## TECHNICAL DATA FOR THE MINI COUNTRYMAN.

Engine <sup>1,2</sup>		Cooper (ALL4)	Cooper D (ALL4)	Cooper S (ALL4)	Cooper SD (ALL4)	Cooper S E ALL4
Cylinders/layout/valves per cylinder		3/inline/4	4/inline/4	4/inline/4	4/inline/4	3/inline/4
Capacity	cm <sup>3</sup>	1499	1995	1998	1995	1499
Stroke/bore	mm	94.6/82	90/84	94.6/82	90/84	94.6/82
Max. output/max. revs	kW/hp/rpm	100/136/4400–6000	110/150/4000	141/192/5000–6000	140/190/4000	100/136/4400
Max. torque/revs	Nm/rpm	220/1400–4300	330/1750–2500	280/1350–4600	[400/1750–2500]	220/1250–4300
Compression ratio/recommended fuel	:1	11/91–98 RON	16.5/diesel	11/91–98 RON	16.5/diesel	11/91–98 RON
<b>Performance<sup>1</sup></b>						
Max. speed	km/h	202 [200] (197 [197])	208 [208] (205 [205])	225 [225] (222 [222])	[220] ([218])	[198]
Electric max. speed	km/h	–	–	–	–	[125]
Acceleration 0–100 km/h	sec.	9.6 [9.6] (9.8 [9.8])	8.9 [8.8] (8.8 [8.7])	7.5 [7.4] (7.3 [7.2])	[7.7] ([7.4])	[6.8]
Acceleration 80–120 km/h (5th gear)	sec.	10.9 [-] (12.2 [-])	9.7 [-] (9.7 [-])	8.4 [-] (9.2 [-])	[-] ([-])	–
<b>Fuel consumption<sup>1,2</sup></b>						
Urban	l/100 km	6.8–6.8 [6.6–6.6] (7.5–7.4 [7.2–7.1])	4.9–4.8 [4.9–4.8] (5.7–5.6 [5.3–5.2])	8.0–7.9 [7.6–7.4] (9.0–8.8 [7.9–7.8])	[5.3–5.1] ([5.6–5.4])	–
Extra-urban	l/100 km	4.9–4.8 [5.0–4.9] (5.4–5.3 [5.4–5.3])	4.1–4 [4.3–4.1] (4.5–4.4 [4.7–4.5])	5.3–5.2 [5.4–5.2] (6.0–5.9 [5.8–5.6])	[4.4–4.3] ([4.8–4.6])	–
Combined	l/100 km	5.6–5.5 [5.6–5.5] (6.2–6.1 [6.1–6.0])	4.4–4.3 [4.5–4.4] (5.0–4.8 [4.9–4.8])	6.3–6.2 [6.2–6.0] (7.1–7.0 [6.6–6.4])	[4.8–4.6] ([5.1–4.9])	[2.3–2.1 <sup>3</sup> ]
Electricity consumption <sup>3</sup>	kWh/100 km	–	–	–	–	[14–13.2 <sup>3</sup> ]
CO <sub>2</sub> emissions (combined cycle)	g/km	128–126 [128–126] (141–139 [138–136])	116–113 [118–115] (130–127 [129–126])	144–141 [141–137] (162–159 [150–146])	[125–121] ([133–129])	[52–49 <sup>3</sup> ]
Tank capacity, approx.	l	51	51	51	51	36
Range	km	925 [925] (835 [850])	1185 [1160] (1065 [1065])	825 [850] (730 [795])	[1110] ([1040])	–
<b>Weight<sup>1</sup>/luggage capacity<sup>4</sup></b>						
Unladen weight (EU) <sup>4</sup>	kg	1440 [1465] (1530 [1545])	1480 [1505] (1560 [1575])	1505 [1535] (1585 [1605])	[1540] ([1610])	[1735]
Max. permitted weight	kg	1950 [1975] (2045 [2060])	2000 [2030] (2090 [2100])	2020 [2050] (2110 [2120])	[2060] ([2130])	[2270]
Max. permitted load	kg	585 [585] (590 [590])	595 [600] (605 [600])	590 [590] (600 [590])	[595] ([595])	[610]
Max. permitted axle load, front/rear	kg	1015 [1045] (1070 [1090])/980 (1030)	1060 [1090] (1105 [1115])/995 (1040)	1060 [1090] (1100 [1120])/1000 (1050)	[1095] ([1125])/1000 (1050)	[1115]/[1200]
Luggage capacity	l	450–1390	450–1390	450–1390	450–1390	405–1275
<b>Wheels</b>						
Tyre dimensions, front/rear		205/65 R16 95W	205/65 R16 95W	225/55 R17 97W	225/55 R17 97W	225/55 R17 97W
Wheel rim dimensions, front/rear		7J x 16 light alloy	7J x 16 light alloy	7.5J x 17 light alloy	7.5J x 17 light alloy	7.5J x 17 light alloy
<b>High-voltage battery capacity</b>						
Electric range (NEDC) <sup>5</sup> /max. total range <sup>4</sup>	km	–	–	–	–	[41–42 <sup>5</sup> ]/500

\* The figures quoted are provisional and have not yet been officially confirmed. The provisional figures for fuel consumption were determined in accordance with the ECE driving cycle.

<sup>1</sup> All figures relate to vehicles with the standard 6-speed manual transmission. Figures in square brackets relate to vehicles with 6-speed/8-speed Steptronic transmission.

<sup>2</sup> All MINI models comply with the EU6 exhaust emissions standard. Fuel consumption is determined in accordance with the ECE driving cycle (as defined in directive 80/1268/EEC), made up of approximately one third urban and two thirds extra-urban driving (based on the distance covered). CO<sub>2</sub> emissions are measured separately from fuel consumption. Figures relate to standard-specification vehicles, and may vary significantly where optional equipment (including wider tyres) is fitted. Figures for fuel consumption and CO<sub>2</sub> emissions may vary depending on the wheels and tyres fitted.

<sup>3</sup> Range and energy consumption may vary due to factors such as driving style, road conditions, external temperature, heating and air conditioning, and preconditioning.

<sup>4</sup> Assuming car is fuelled to 90% of usable tank capacity, and allowing 68 kilograms for the driver and 7 kilograms for luggage. Figure quoted is for standard-specification vehicles. Optional equipment will increase this figure.

<sup>5</sup> The lower value applies to the 17" and 18" standard wheels without runflat tyres (option 258).

## MINI COUNTRYMAN DIMENSIONS.

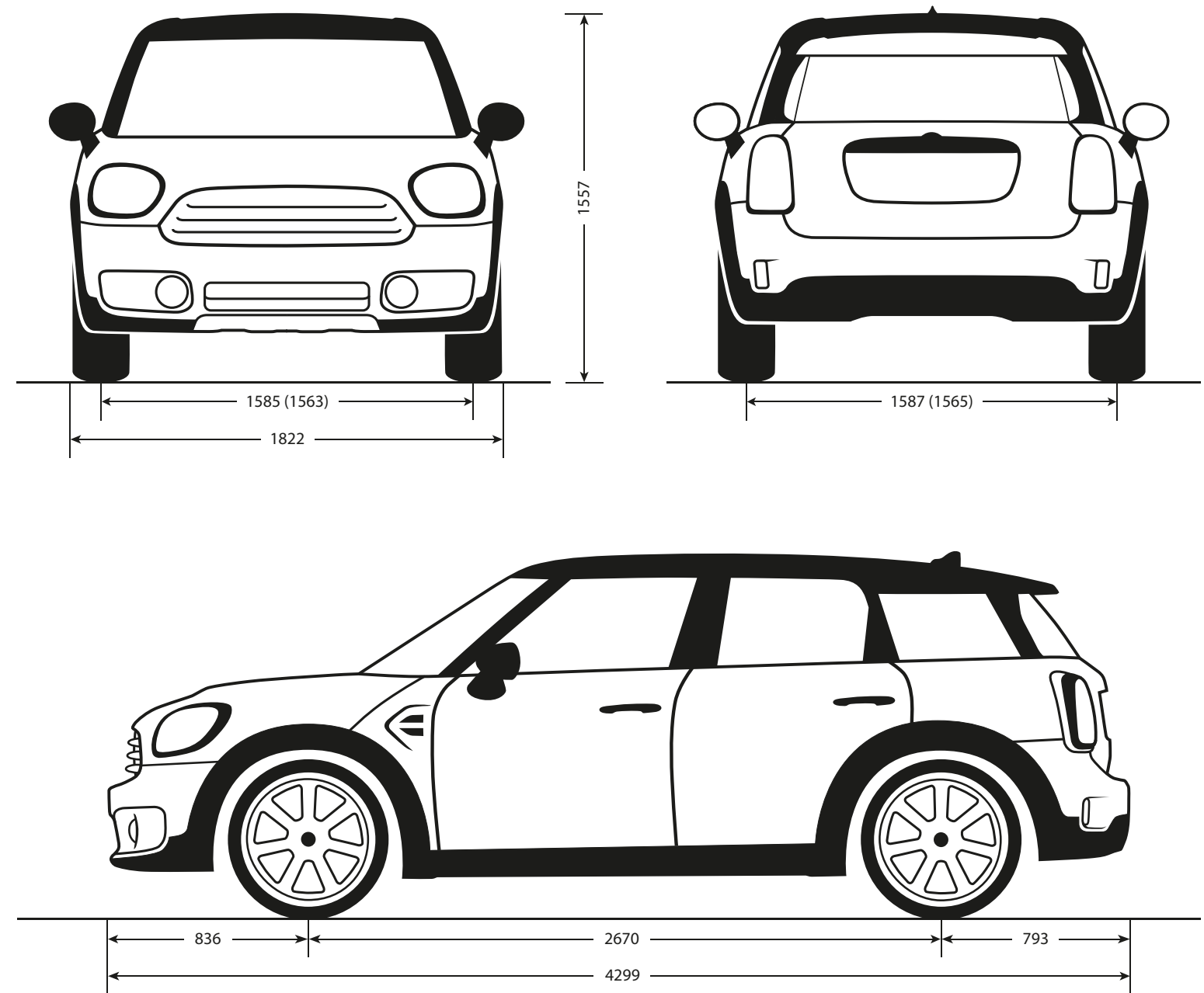

Cooper S/SD figures in brackets.  
All figures in mm.



## THIS IS WHERE THE FUN REALLY STARTS.

What's the point of revving yourself up without taking it for a spin? Get behind the wheel. Make yourself comfortable in the driver's seat. Listen to the satisfying sound the door makes as it closes behind you. Fasten your seat belt. Adjust the rear-view mirror and start the engine. A whole new experience awaits you: a drive like no other, guaranteed to inspire. So what are you waiting for? Arrange a test drive with your MINI dealer and find out what it feels like to drive a MINI Countryman.

[mini.com](http://mini.com)



The models, standard and optional equipment and combinability of options in this catalogue relate to cars supplied by BMW AG for the German market. The availability of standard and optional equipment, and configurations of options, may vary for all models in this brochure after going to press (on 19 Dec 2016), and may vary from country to country within the European Union. For detailed information about the situation in your country, please contact your authorized MINI dealer. Subject to changes in design and equipment.

© BMW AG, Munich, Germany.  
Not to be reproduced,  
wholly or in part, without the written  
permission of BMW AG, Munich.

For more information, visit  
**mini.com** or contact  
MINI customer service.  
Phone: 0800 000 6464



[facebook.com/mini](https://www.facebook.com/mini)

MINI ORIGINAL ACCESSORIES  
[mini.com/accessories](https://www.mini.com/accessories)

MINI COLLECTION  
[shop.mini.com](https://shop.mini.com)

March 2017

